



Stepping Motors



Stepping Motors

Introduction A-2	Introduction
AC Input Stepping Motor and Driver Packages	0.36° High Efficiency <i>α</i>STEP AR Series A-24	<i>α</i>STEP AR / Geared
	0.36° <i>α</i>STEP AS Series A-68	<i>α</i>STEP AS
	0.72° RK Series A-78	RK / Geared
	0.9°/1.8° UMK Series A-114	UMK / Geared
DC Input Stepping Motor and Driver Packages	0.36° High Efficiency <i>α</i>STEP AR Series A-116	<i>α</i>STEP AR / Geared
	0.36° <i>α</i>STEP ASX Series A-164	<i>α</i>STEP ASX / Geared
	0.36°/0.72° CRK Series A-168	CRK / Geared
	0.9°/1.8° CMK Series A-218	CMK / Geared
	1.8° RBK Series A-244	RBK / Geared
Stepping Motors (Motor Only) A-269	0.36° PK Series A-290	PK / Geared
	0.72° PK Series A-291	PK / Geared
	0.9° PK Series A-294	PK / Geared
	1.8° PK Series/PV Series A-302	PK/PV / Geared
	Geared Motor PK Series A-334	PK / Geared
Controllers A-357	Controllers 5CK110 EMP400 /5G80301
Accessories A-393	Accessories

This catalog contains information necessary for informed product selection. Additional product details and information not outlined in this catalog can be found in each product's individual operating manual. Operating manuals can be downloaded from our website or obtained by contacting technical support or your nearest Oriental Motor sales office.

Overview of Stepping Motors

Stepping motors enable accurate positioning operation with ease.

They are used in various types of equipment for accurate rotation angle and speed control using pulse signals.

Features

Accurate Positioning in Fine Steps

A stepping motor rotates with a fixed step angle, just like the second hand of a clock. This angle is called "basic step angle." Oriental Motor offers four basic step angles (0.36°, 0.72°, 0.9°, 1.8°).

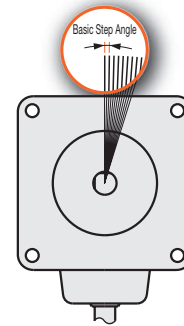

Four Basic Step Angles

- 0.36°
- 0.72°
- 0.9°
- 1.8°

Easy Control with Pulse Signals

A system configuration for high accuracy positioning is shown below. The rotation angle and speed of the stepping motor can be controlled accurately using pulse signals from the controller.

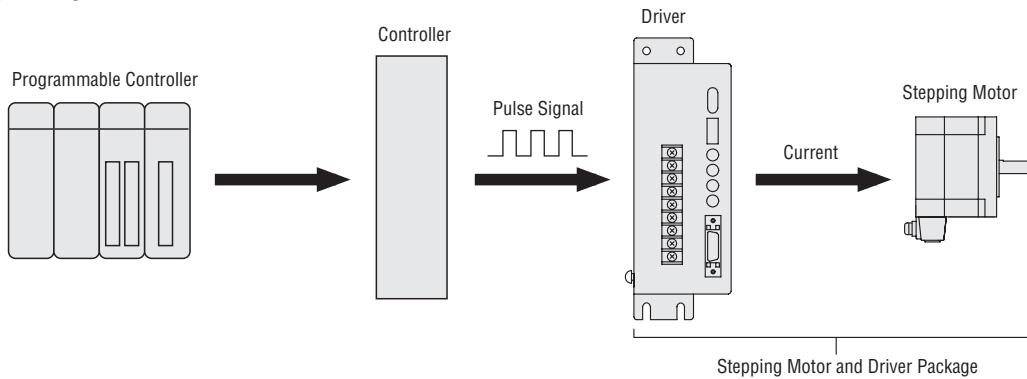

What is a Pulse Signal?

A pulse signal is an electrical signal whose voltage level changes repeatedly between ON and OFF. Each ON/OFF cycle is counted as one pulse. A command with one pulse causes the motor output shaft to turn by one step.

The signal levels corresponding to voltage ON and OFF conditions are referred to as "H" and "L", respectively.

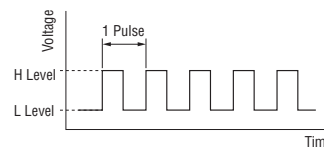

The Amount of Rotation is Proportional to the Number of Pulses

The amount of rotation of the stepping motor is proportional to the number of pulse signals (pulse number) given to the driver.

The relationship of the stepping motor's rotation (rotation angle of the motor output shaft) and pulse number is expressed as follows:

$$\theta = \theta_s \times A$$

θ : Rotation angle of the motor output shaft [deg]
 θ_s : Step angle [deg/step]
 A : Pulse number [pulses]

The Speed is Proportional to the Pulse Speed

The speed of the stepping motor is proportional to the speed of pulse signals (pulse frequency) given to the driver.

The relationship of the pulse speed [Hz] and motor speed [r/min] is expressed as follows:

$$N = \frac{\theta_s}{360} \times f \times 60$$

N : Speed of the motor output shaft [r/min]
 θ_s : Step angle [deg/step]
 f : Pulse speed [Hz]
 (Number of pulses input per second)

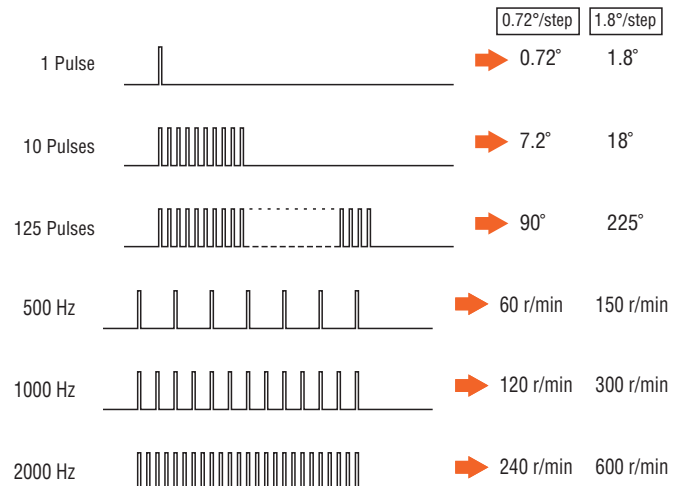

● Generating High Torque with a Compact Body

Stepping motors generate high torque with a compact body. These features give them excellent acceleration and response, which in turn makes these motors well-suited for torque-demanding applications where the motor must be started and stopped frequently. To meet the need for greater torque at low speed, Oriental Motor also has geared motors combining compact design and high torque.

◇ Frequent Starting/Stopping is Possible

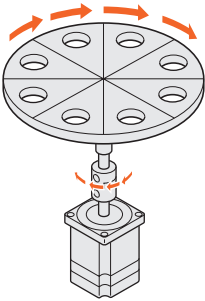

◇ Speed – Torque Characteristics [Motor frame size 60 mm (2.36 in.)]

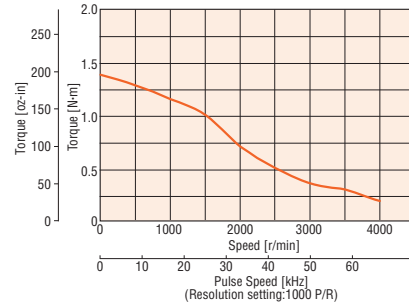

● The Motor Holds Itself at a Stopped Position

Stepping motors continue to generate holding torque even at standstill. This means that the motor can be held at a stopped position without using a mechanical brake.

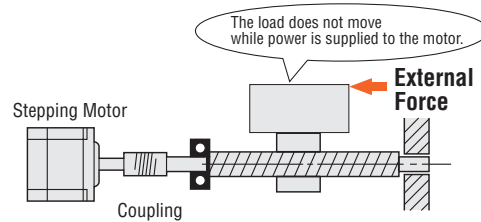

● Capable of Driving Large Inertial Loads

Stepping motors can drive larger inertial loads than servo motors of equivalent frame sizes.

● Comparison at 30 times of the rotor inertia

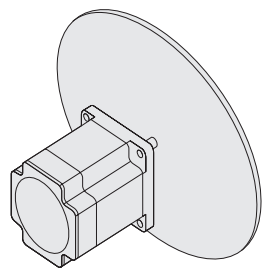

Stepping Motors

Load Inertia $22.4 \times 10^{-4} \text{ kg}\cdot\text{m}^2$ (123 oz-in²)
(30 times the rotor inertial moment)

Load Inertia: Diameter: 169 mm (6.65 in.)
Thickness: 10 mm (0.39 in.)
Material: Aluminum
Motor: Frame size 60 mm (2.36 in.)
Length 90 mm (3.54 in.)

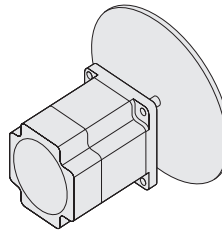

Conventional Servo Motor

Load Inertia $4.0 \times 10^{-4} \text{ kg}\cdot\text{m}^2$ (22 oz-in²)
(30 times the rotor inertia)

Load Inertia: Diameter: 110 mm (4.33 in.)
Thickness: 10 mm (0.39 in.)
Material: Aluminum
Motor: Frame size 60 mm (2.36 in.)
Length 96.5 mm (3.8 in.)

● 0.36° Closed Loop Stepping Motor and Driver Package

αSTEP

These products use our closed loop control to maintain positioning operation even during abrupt load fluctuations and accelerations. The rotor position detection sensor monitors the rotation. When an overload condition is detected, it will instantaneously regain control using the closed loop mode. When an overload condition continues, it will output an alarm signal, thereby providing reliability equal to that of a servo motor.



AR Series AC Input → Page A-24
AR Series DC Input → Page A-118

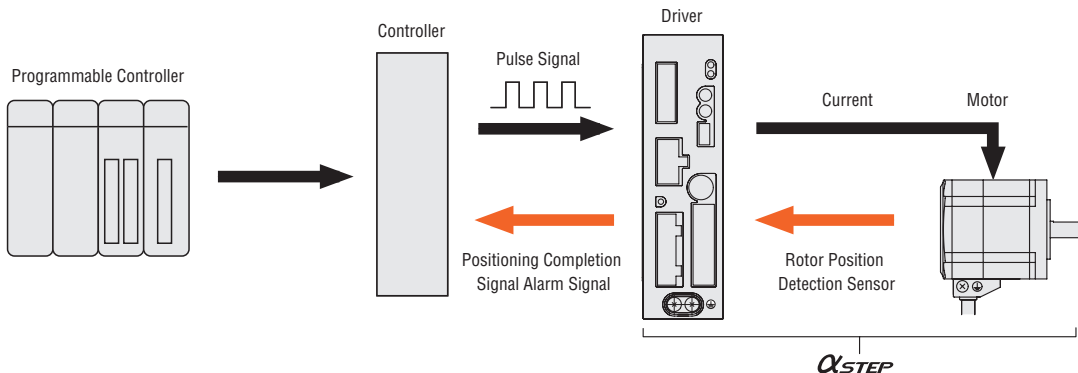

Introduction

AC Input Motor & Driver

AR 0.36° / Geared

AS 0.72° / Geared

RK 0.9°/1.8°

UMK 0.9°/1.8°

DC Input Motor & Driver

AR 0.36° / Geared

ASX 0.36° / Geared

CRK 0.36°/0.72° / Geared

CMK 0.9°/1.8° / Geared

RBK 1.8° / Geared

PK 0.36°

PK 0.72°

PK 0.9°

Motor Only

PK 1.8°

PK/PV 1.8°

Geared

PK

Controllers

SCX10

EMP400

/SG8030J

Accessories

Motor Types

Stepping motors come in several different types including the standard type, electromagnetic brake type and various geared types. The availability of such a wide selection means that you can choose an optimal type according to the function and performance required in your specific application.

Typical examples are introduced below.

Standard Type

A basic model that is easy to use and designed with a balanced set of functions and characteristics.



Electromagnetic Brake Type

These motors incorporate a non-excitation type electromagnetic brake. When the power is accidentally cut off due to power outage or other unexpected event, the electromagnetic brake holds the load in position to prevent it from dropping or moving.

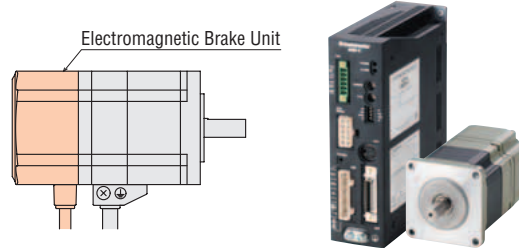

High-Torque Type

A high-torque motor has a higher torque of approximately 1.5 times compared with the conventional standard type motor.

The use of a smaller motor allows for compact equipment design.



Once the power is cut off, the self-holding torque of the motor is lost and the motor can no longer be held at the stopped position in vertical operations or when an external force is applied. In lift and similar applications, use an electromagnetic brake type.

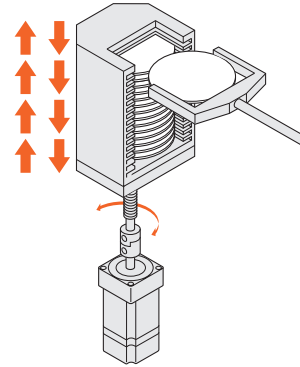

Standard Type Industrial Connector

These motors conform to the IP65 rating for protection against dust and water ingress.

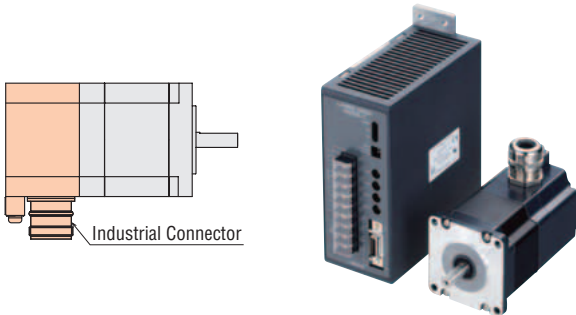

Geared Type

These motors incorporate a dedicated position-control gearhead with reduced backlash to make the most of the high controllability of the motors. The gearhead ensures highly accurate, smooth operation even in applications where a large torque is received.

Advantages of Geared Motors → Page A-6

Geared Motor Line-Up → Page A-7

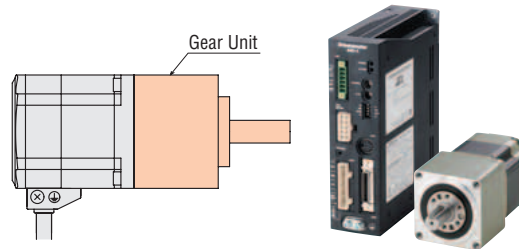

◇ AR Series Geared Type Typical Characteristics

Geared Type	Permissible Torque [N·m (lb-in)]	Backlash [min]	Resolution [°/pulse]	Speed [r/min]
TH Geared Type	12 (106)	45	0.012	500
PS Geared Type	37 (320)	25	0.0072	600
PN Geared Type	37 (320)	3	0.0072	600
Harmonic Geared Type	37 (320)	0	0.0036	70

● The values shown above are reference. These values vary depending on the product.

Types of Operation Systems

Each stepping motor and driver package combines a stepping motor selected from various types with a dedicated driver. Drivers that operate in the pulse input mode and built-in controller mode are available. You can select a desired combination according to the required operation system. Typical examples are shown below.

Pulse Input Package

The motor can be controlled using a pulse generator provided by the user. Operation data is input to the pulse generator beforehand. Select the operation data on the host programmable controller, then input the operation command.

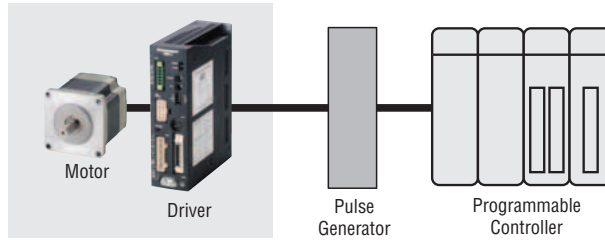

Built-In Controller Package

The built-in pulse generation function allows the motor to be driven via a directly connected personal computer or programmable controller. Since no separate pulse generator is required, drivers of this type save space and simplify wiring.

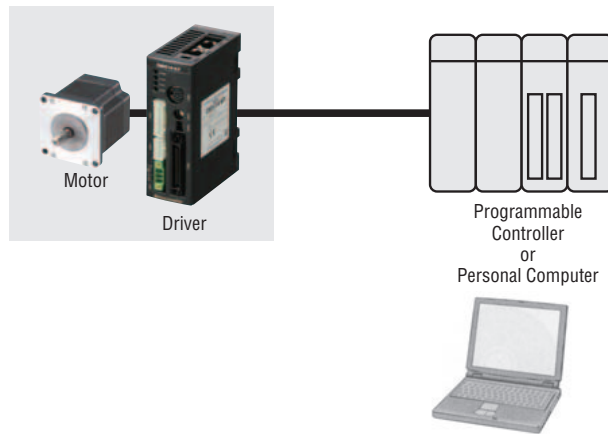

Introduction
DC Input Motor & Driver
AR 0.36° / Geared
ASX 0.36° / Geared
AS 0.36° / Geared
RK 0.72° / Geared
UMK 0.9°/1.8°
DC Input Motor & Driver
AR 0.36° / Geared
ASX 0.36° / Geared
CRK 0.36°/0.72° / Geared
CMK 0.9°/1.8° / Geared
RBK 1.8° / Geared
Motor Only
PK 0.36°
PK 0.72°
PK 0.9°
PK/PV 1.8°
PK Geared
Controllers
SCX10
EMP400
SG8030J
Accessories

Advantages of Geared Motors

We offer motors pre-assembled with gears, as variations of stepping motors. Geared motors not only achieve deceleration, high torque and high resolution, but they also provide the additional advantages:

Capable of Driving Large Inertial Loads

When a geared motor is used, the inertial load that can be turned increases in comparison with a comparable standard motor in proportion to the square of the gear ratio. This means that larger inertial loads can be driven with geared motors.

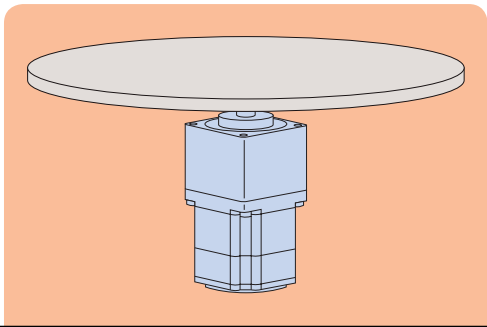
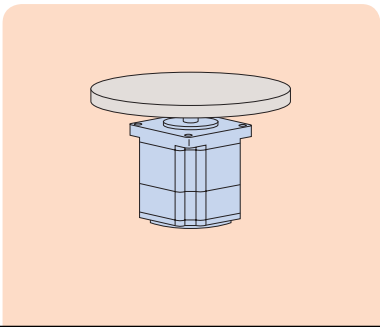
		
Motor Type	Geared Motor (Gear Ratio: 5)	Standard Motor
Model Name	AR66AA-N5-3	AR66AA-3
Load Inertia (30 times the rotor inertia)	$285 \times 10^{-4} \text{ kg}\cdot\text{m}^2$ (1560 oz-in)	$11.4 \times 10^{-4} \text{ kg}\cdot\text{m}^2$ (62 oz-in)
Diameter of Load Inertia (Thickness: 10 mm, Material: Aluminum)	319 mm (12.6 in.)	143 mm (5.63 in.)

Improved Damping Characteristics at Start and Stop

If the inertial load is large or acceleration/deceleration time is short, a geared motor can increase damping more effectively and thereby ensure more stable operation compared to a standard motor. Geared motors are ideal for applications where a large inertia such as an index table or arm must be driven to perform quick positioning.

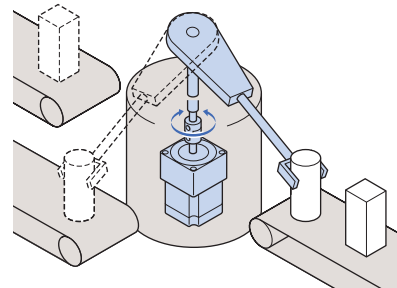
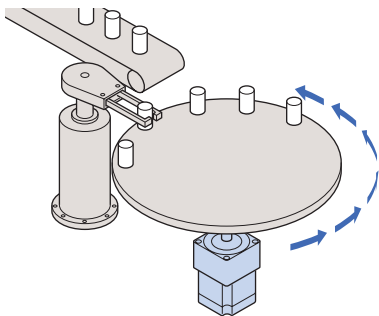

Smaller Size

When a standard motor is compared with a geared motor that generates equivalent torque at low speed, the geared motor has a smaller frame size, thus its mass and volume are also smaller.

Geared motors are effective when equipment must be kept small and light.

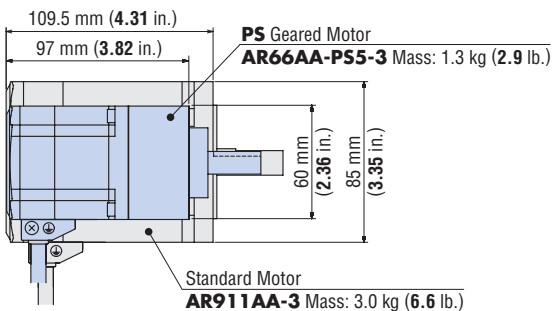

● High Rigidity, Resistant to Torsional Force

Geared motors have high rigidity and are therefore resistant to torsional force. Compared to standard motors, geared motors are less subject to load torque fluctuation. This means that stability and high positioning accuracy can be ensured even when the load size changes.

◇ Applications: Elevator

The application can be stopped accurately even with elevators and other mechanisms that perform vertical operations where the number of loads or weight of loads changes.

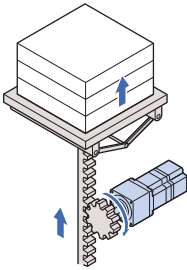

◇ Applications: Security Camera

The position can be held securely even when the camera sways due to strong wind.

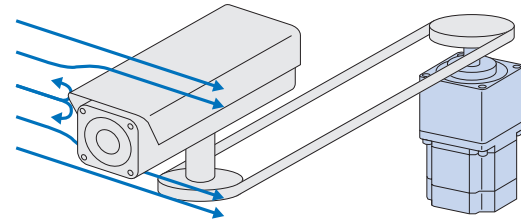

● Surface Installation of Load (Harmonic geared type)

The harmonic geared type permits installation of a load directly on the rotating surface integrated with the shaft. [Except for geared motors with a frame size of 90 mm (3.54 in.)]

◇ Appearance and Installation Example

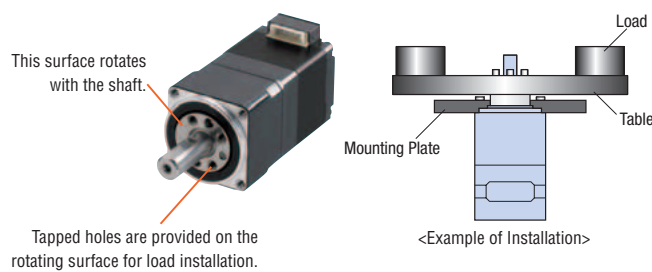



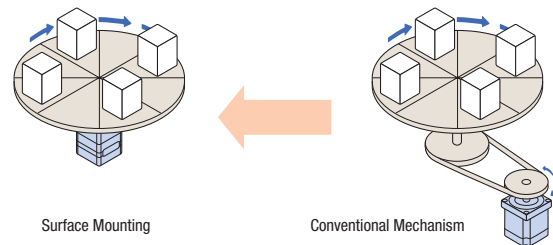

◇ Application: Index Table

This not only reduces the number of parts/processes, but also improves reliability. They are also suitable for operating loads that receive moment loads.



■ Geared Motor Line-Up

Example of AR Series

	Geared Type	Features	Permissible Torque Maximum Torque [N·m (lb-in)]	Backlash [arc min (degrees)]	Basic Resolution [deg/step]	Output Shaft Speed [r/min]
Low backlash	TH Geared Type (Parallel shaft) 	<ul style="list-style-type: none"> A wide variety of low gear ratios, high-speed operations Gear ratios: 3.6, 7.2, 10, 20, 30 	12 (106)	45 (0.75)	0.012	500
	PS Geared Type (Planetary) 	<ul style="list-style-type: none"> High Speed (low gear ratio) High permissible/maximum torque A wide variety of gear ratios for selecting the desired step angle (resolution) Centered output shaft Gear ratios: 5, 7.2, 10, 25, 36, 50 	Permissible Torque 37 (320) Maximum Torque 60 (530)	25 (0.42)	0.0072	600
Non-backlash	PN Geared Type (Planetary) 	<ul style="list-style-type: none"> High speed (low gear ratio), high accuracy positioning High permissible/maximum torque A wide variety of gear ratios for selecting the desired step angle (resolution) Centered output shaft Gear ratios: 5, 7.2, 10, 25, 36, 50 	Permissible Torque 37 (320) Maximum Torque 60 (530)	3 (0.05)	0.0072	600
	Harmonic Geared Type (Harmonic drive) 	<ul style="list-style-type: none"> High accuracy positioning High permissible/maximum torque High gear ratios, high resolution Centered output shaft Gear ratios: 50, 100 	Permissible Torque 37 (320) Maximum Torque 55 (480)	0	0.0036	70

Notes

- The values shown above must be used as reference. These values vary depending on the frame size and gear ratio.
 - For the principle and the structure of each geared type, refer to technical reference.
- For stepping motor and servo motor gears → Page G-68

Introduction

DC Input Motor & Driver

AR /Geared 0.36°

AS /Geared 0.72°

RK /Geared 0.9°/1.8°

UMK 0.9°/1.8°

AR /Geared 0.36°

ASX /Geared 0.36°

CRK /Geared 0.36°/0.72°

CMK /Geared 0.9°/1.8°

RBK /Geared 1.8°

PK 0.36°

PK 0.72°

PK 0.9°

PK/PV 1.8°



PK Geared

Controllers
SCX10
EMP400
/SG8030J

Accessories

Product Line-Up of Stepping Motors

The stepping motor product lines are shown by systems for each category and series. Refer to "Type of Stepping Motors" on page A-10 for a comparison of the series.

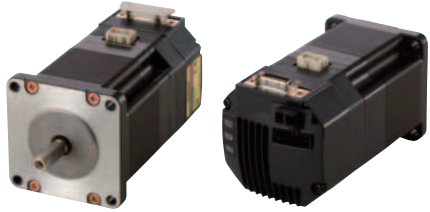
Step Angle 0.36° (Resolution Setting: 1000 P/R) Closed Loop Stepping Motor and Driver Package <i>αSTEP</i>	
AC Input Motor and Driver Packages	<div style="display: flex; justify-content: space-around;"> <div style="width: 45%;"> <p>0.36° High-Efficiency AR Series</p>  <ul style="list-style-type: none"> • High-efficiency, lower heat generation • Continuous operation, extended functions • Closed loop, no hunting, no gain tuning • Wide variety of motors </div> <div style="width: 45%;"> <p>0.36° AS Series Built-In Controller</p>  <ul style="list-style-type: none"> • Closed loop, no hunting, no gain tuning • RS-232 Communications • Up to 36 units daisy chained • Wide variety of motors </div> </div>
DC Input Motor and Driver Packages	<div style="display: flex; justify-content: space-around;"> <div style="width: 45%;"> <p>0.36° High-Efficiency AR Series</p>  <ul style="list-style-type: none"> • High-efficiency, lower heat generation • Continuous operation, extended functions • Closed loop, no hunting, no gain tuning • Wide variety of motors </div> <div style="width: 45%;"> <p>0.36° ASX Series</p>  <ul style="list-style-type: none"> • Motor, driver, controller and feedback system in one unit • Closed loop, no hunting, no gain tuning • RS-232 communications • GUI software available </div> </div>
Motor Only	



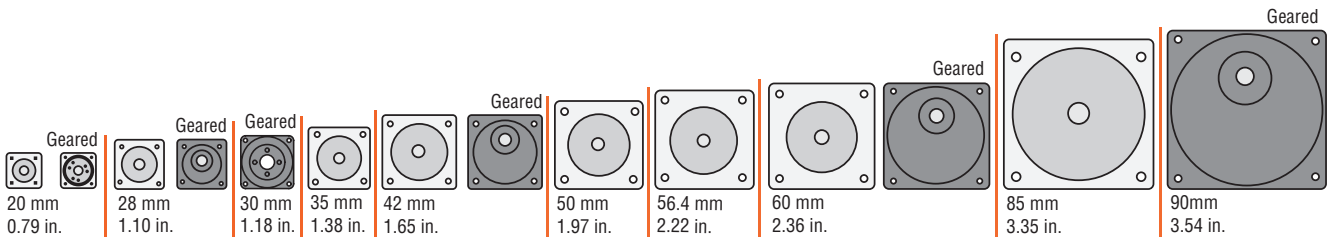

● Wide Range of Motor Frame Size



Note
● The motor frame sizes in the lineup differ by series. For details, confirm the individual product page.

Step Angle 0.36°/0.72° Stepping Motor and Driver Package		Step Angle 0.9°/1.8° Stepping Motor and Driver Package	
<p>0.72° RK Series</p> <p>Encoder</p>  <ul style="list-style-type: none"> • Lowest vibration, lowest noise • Wide variety of motors 		<p>0.9°/1.8° UMK Series</p>  <ul style="list-style-type: none"> • Standard performance • Basic functionality 	
<p>0.36°/0.72° CRK Series Pulse Input</p> <p>Encoder</p>  <ul style="list-style-type: none"> • Lowest vibration, lowest noise • Compact driver • Wide variety of motors 	<p>0.36°/0.72° CRK Series Built-in Controller</p> <p>Encoder</p>  <ul style="list-style-type: none"> • Lowest vibration, lowest noise • RS-485 Communications • Multi-drop up to 16 units • GUI software available • Wide variety of motors 	<p>0.9°/1.8° CMK Series</p> <p>Encoder</p>  <ul style="list-style-type: none"> • Low vibration, low noise • Compact driver • Wide variety of motors 	<p>1.8° RBK Series</p> <p>Encoder</p>  <ul style="list-style-type: none"> • Low vibration, low noise • Highest torque for entire speed range • Wide variety of motors
<p>0.36°/0.72° PK Series</p> <p>Encoder</p>  <ul style="list-style-type: none"> • Wide variety of motors 		<p>0.9°/1.8° PK/PV Series</p> <p>Encoder</p>  <ul style="list-style-type: none"> • Wide variety of motors 	

● Geared Motor Line-Up

For 1.8° Stepping Motor	Low Backlash		Non-Backlash	
SH Geared Type (Parallel Shaft)	TH Geared Type (Parallel Shaft)	PS/PL Geared Type (Planetary Gear)	PN Geared Type (Planetary Gear)	Harmonic Geared Type (Harmonic Gear)
				

Note

● Confirm the each product page for the features and lineups of each geared type.

Type of Stepping Motors

One feature of stepping motors is that they can perform accurate positioning operation with ease. So that more users can enjoy the benefits of stepping motors, Oriental Motor has many different product series designed with different power supply specifications and different functions. There is also a wide spectrum of variations within each series, as models come in different frame sizes and with or without an electromagnetic brake and different gear types.

AC Input Motor and Driver Packages

Category	AC Input, Motor and Driver Package	
Series	0.36° αSTEP High-Efficiency AR Series 	0.72° RK Series 
Page	A-24	A-78
Features	<ul style="list-style-type: none"> • High-efficiency, lower heat generation • Continuous operation, extended functions • Closed loop, no hunting, no gain tuning • Wide variety of motors 	<ul style="list-style-type: none"> • Lowest vibration, lowest noise • Wide variety of motors
Control Method	Closed loop control	Open loop
Basic Step Angle	0.36° (Resolution setting: 1000 P/R)	0.72°
Excitation Method	Microstep	Microstep
Resolution	3.6°~0.036°	0.72°~0.00288° (16 steps)
Driver Type		
	Pulse Input ●	●
	Built-In Controller –	–
	Network –	–
Motor Frame Size		
	□20 (□0.79) –	–
	□28 (□1.10), □30 (□1.18), □35 (□1.38) –	–
	□42 (□1.65) ●	●
	□50 (□1.97) –	–
	□56.4 (□2.22), □60 (□2.36) ●	●
	□85 (□3.35), □90 (□3.54) ●	●
Function		
	Electromagnetic Brake ●	–
	Encoder –	●
	Terminal Box –	●
Geared Type		
	SH Gear (Parallel Shaft) –	–
	TH Gear (Parallel Shaft) ●	●
	PS/PL Gear (Planetary Gear) ●	●
	PN Gear (Planetary Gear) ●	●
	Harmonic Gear ●	●
Power Supply Input	Single-Phase 100-115 VAC Single-Phase 200-230 VAC Three-Phase 200-230 VAC	Single-Phase 100-115 VAC Single-Phase 200-230 VAC
Safety Standard		

Stepping Motors (Motor Only)

Category	Stepping Motors (Motor Only) 0.36°, 0.72°, 0.9°, 1.8°, Geared
Series	PK Series, PV Series 
Page	A-269
Features	<ul style="list-style-type: none"> • 4 basic step angles available (0.36°, 0.72°, 0.9°, 1.8°) • Many motor frame sizes available • Wide variety of motors • Encoder motors available

DC Input, Motor and Driver Package				
0.36° <i>Q</i> STEP High-Efficiency AR Series	0.36°/0.72° CRK Series Pulse Input	0.36°/0.72° CRK Series Built-In Controller	0.9°/1.8° CMK Series	1.8° RBK Series
A-116	A-168	A-168	A-218	A-244
<ul style="list-style-type: none"> High-efficiency, lower heat generation Continuous operation, extended functions Closed loop, no hunting, no gain tuning Wide variety of motors 	<ul style="list-style-type: none"> Lowest vibration, lowest noise Compact driver Wide variety of motors 	<ul style="list-style-type: none"> Lowest vibration, lowest noise RS-485 Communications Multi-drop up to 16 units GUI software available Wide variety of motors 	<ul style="list-style-type: none"> Low vibration, low noise Compact driver Wide variety of motors 	<ul style="list-style-type: none"> Low vibration, low noise Highest torque for entire speed range Wide variety of motors
Closed loop control	Open loop	Open loop	Open loop	Open loop
0.36° (Resolution setting: 1000 P/R)	0.36°/0.72°	0.36°/0.72°	0.9°/1.8°	1.8°
Microstep	Microstep	Microstep	Microstep	Microstep
3.6°~0.036°	0.36°: 0.9°~0.00144° (16 steps) 0.72°: 1.8°~0.00288° (16 steps)	0.36°: 0.9°~0.00144° (16 steps) 0.72°: 1.8°~0.00288° (16 steps)	0.9°: 0.9°~0.05625° (5 steps) 1.8°: 1.8°~0.1125° (5 steps)	1.8°~0.0140625° (16 steps)
●	●	●	●	●
—	—	—	—	—
—	—	RS-485	—	—
—	●	●	●	●
●	●	●	●	●
●	●	●	●	●
—	—	—	●	●
●	—	—	●	●
●	—	—	—	—
—	●	●	●	●
—	—	—	—	—
—	—	—	●	—
●	●	●	—	—
●	●	●	—	—
●	●	●	—	—
●	●	●	—	—
24/48 VDC	24 VDC	24 VDC	24 VDC	Standard Type: 20~75 VDC High-Torque Type, PS/PL Geared Type: 20~40 VDC
CE	UL US CE	CE		UL US * CE *

Other Stepping Motor and Driver Packages

Category	AC Input Stepping Motor and Driver Packages		DC Input Stepping Motor and Driver Packages
	0.36° <i>Q</i> STEP AS Series Built-In Controller	0.9°/1.8° UMK Series	0.36° <i>Q</i> STEP-One ASX Series
Series			
Page	A-68	A-114	A-164
Features	<ul style="list-style-type: none"> Closed loop, no hunting, no gain tuning RS-232 Communications Up to 36 units daisy chained Wide variety of motors 	<ul style="list-style-type: none"> Standard performance Basic functionality 	<ul style="list-style-type: none"> Motor, driver, controller and feedback system in one unit Closed loop, no hunting, no gain tuning RS-232 communications GUI software available

How to Read Specifications Table

Model	Single-Phase 100-115 VAC		RK564AAE	RK566AAE-N5
	Single Shaft	Double Shaft	RK564BAE	RK566BAE-N5
Single-Phase 200-230 VAC	With Encoder		RK564AAE-R27	—
	Single Shaft	Double Shaft	RK564ACE	RK566ACE-N5
		With Encoder	RK564BCE	RK566BCE-N5
			RK564ACE-R27	—
①	Maximum Holding Torque	N-m (lb-in)	0.42 (59 oz-in)	3.5 (30)
②	Rotor Inertia	J: kg-m ² (oz-in ²)	175×10 ⁻⁷ (0.96)	280×10 ⁻⁷ (1.53)
③	Rated Current	A/Phase	1.4	
④	Basic Step Angle		0.72°	0.144°
⑤	Gear Ratio		—	5
⑥	Permissible Torque	N-m (lb-in)	—	3.5 (30)
⑦	Maximum Torque	N-m (lb-in)	—	7 (61)
⑧	Holding Torque at Motor Standstill	Power ON N-m (lb-in)	0.21 (29 oz-in)	2 (17.7)
⑨	Backlash	arc min (degrees)	—	2 (0.034°)
⑩	Permissible Speed Range	r/min	—	0-600
⑪	Power Source		Single-Phase 100-115 VAC±15% 50/60 Hz 4.5 A Single-Phase 200-230 VAC±10% 50/60 Hz 3.5 A	
⑫	Excitation Mode		Microstep	

① Maximum Holding Torque

The holding torque (Step angle 0.36° and 0.72°: 5-phase excitation, Step angle 0.9° and 1.8°: 2-phase excitation) is the maximum holding power (torque) the stepping motor has when power (rated current) is being supplied but the motor is not rotating (with consideration given to the permissible strength of the gear when applicable). At motor standstill, the driver's automatic current cutback function reduces the maximum holding torque by approximately 50% (approximately 40% for **CMK** Series).

② Rotor Inertia

This refers to the inertia of rotor inside the motor. This is necessary when the required torque (acceleration torque) for the motor needs are calculated.

③ Rated Current

The rated current is determined by motor temperature rise. It is the current value that can flow to the motor coils continuously at motor standstill. As a general rule, the current must be set to the rated current.

④ Basic Step Angle

The step angle is the angular distance (in degrees) that the motor moves at the input of one pulse from the driver. It differs depending on the motor structure and excitation mode.

⑤ Gear Ratio

This is the ratio in rotation speed between the input speed from the motor and the speed of the gear output shaft. For example, the gear ratio 10:1 is that when the input speed from the motor is 10 r/min, the gear output shaft is 1 r/min.

⑥ Permissible Torque

The permissible torque represents the torque value limited by the mechanical strength of the gear when operated at a constant speed. For the types excluding **PL**, **PS**, **PN** and harmonic geared types, the total torque including acceleration/deceleration torque should not exceed this value.

⑦ Maximum Torque (**PS** geared, **PN** geared, harmonic geared type only)

This is the maximum torque that can be used instantaneously (for a short time). During acceleration/deceleration, the motor can be operated up to this value.

⑧ Holding Torque at Motor Standstill

When powered on: The holding torque with the automatic current cutback function working (the factory setting).
Electromagnetic brake: The static friction torque that the electromagnetic brake can generate when stopped (power off activated type).

⑨ Backlash

The play of gear output shaft when the motor shaft is fixed. When positioning in bi-direction, the positioning accuracy is affected.

⑩ Permissible Speed Range

This is the rotation speed that the motor can be operated at with the gear output shaft.

⑪ Power Source

The current value of the power input is the maximum input current value. (The input current varies according to the rotation speed.)

⑫ Excitation Mode

The driver has a function that can change the motor's step angle. Shown in the table is the step angle value at which the motor can be operated. (For the step angle value of microstep, see "Connection and Operation.")

How to Read Speed – Torque Characteristics

The graph below are the characteristics that indicate the relationship between the speed and torque when a stepping motor is driven. The required speed and torque is always used when selecting a stepping motor. On the graph, the horizontal axis expresses the speed at motor output shaft while the vertical axis expresses the torque.

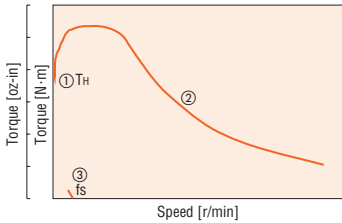

The speed – torque characteristics are determined by the motor and driver, so they vary greatly based upon the type of the driver used.

① Maximum Holding Torque (T_H)

The holding torque (Step angle 0.36° and 0.72°: 5-phase excitation, Step angle 0.9° and 1.8°: 2-phase excitation) is the maximum holding power (torque) the stepping motor has when power (rated current) is being supplied but the motor shaft is not rotating. At motor standstill, the driver's automatic current cutback function reduces the maximum holding torque by approximately 50% (approximately 40% for **CMK** Series).

② Pullout Torque

Pullout torque is the maximum torque that can be output at a given speed. When selecting a motor, be sure the required torque falls within this curve.

③ Maximum Starting Frequency (f_s)

This is the maximum pulse speed at which the motor can start or stop instantaneously (without an acceleration or deceleration time) when the frictional load and inertial load of the stepping motor are 0. Driving the motor at greater than this pulse speed requires gradual acceleration or deceleration. This frequency drops when there is an inertial load on the motor. (Refer to Inertial load – starting frequency characteristics in technical reference → Page G-38)

The following figure shows the speed – torque characteristics of the 0.72° stepping motor and driver package **RK** Series.

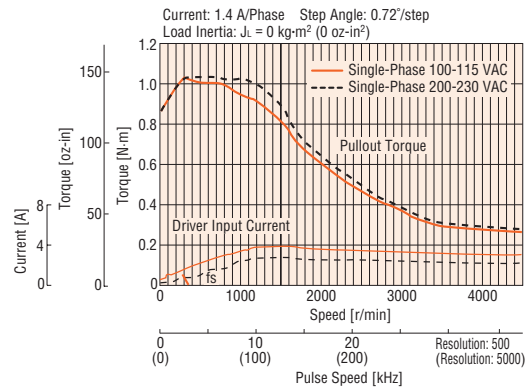

Common Specifications

Permissible Overhung Load and Permissible Thrust Load

AR Series

Unit = N (lb.)

Type	Motor Frame Size mm [in.]	Model	Gear Ratio	Permissible Overhung Load Distance from Shaft End mm [in.]					Permissible Thrust Load
				0 [0]	5 [0.2]	10 [0.39]	15 [0.59]	20 [0.79]	
Standard Type	28 [1.10]	AR24	-	25 (5.6)	34 (7.6)	52 (11.7)	-	-	1.5 (0.33)
		AR26							2.2 (0.49)
	42 [1.65]	AR46		35 (7.8)	44 (9.9)	58 (13)	85 (19.1)	-	4.6 (1.03) [6.1 (1.37)]*
	60 [2.36]	AR66		90 (20)	100 (22)	130 (29)	180 (40)	270 (60)	8.8 (1.98) [11.8 (2.6)]*
		AR69							13.7 (3) [16.7 (3.7)]*
	85 [3.35]	AR98						18 (4) [24 (5.4)]*	
		AR911		260 (58)	290 (65)	340 (76)	390 (87)	480 (108)	29 (6.5)
TH Geared Type	28 [1.10]	AR24	7.2, 10, 20, 30	15 (3.3)	17 (3.8)	20 (4.5)	23 (5.1)	-	10 (2.2)
	42 [1.65]	AR46	3.6, 7.2, 10, 20, 30	10 (2.2)	14 (3.1)	20 (4.5)	30 (6.7)	-	15 (3.3)
	60 [2.36]	AR66		70 (15.7)	80 (18)	100 (22)	120 (27)	150 (33)	40 (9)
	90 [3.54]	AR98		220 (49)	250 (56)	300 (67)	350 (78)	400 (90)	100 (22)
PS Geared Type	28 [1.10]	AR24	5, 7.2, 10	45 (10.1)	60 (13.5)	80 (18)	100 (22)	-	20 (4.5)
	42 [1.65]	AR46	5, 7.2, 10	73 (16.4)	84 (18.9)	100 (22)	123 (27)	-	50 (11.2)
				109 (24)	127 (28)	150 (33)	184 (41)	-	
	60 [2.36]	AR66	5	200 (45)	220 (49)	250 (56)	280 (63)	320 (72)	100 (22)
				250 (56)	270 (60)	300 (67)	340 (76)	390 (87)	
				330 (74)	360 (81)	400 (90)	450 (101)	520 (117)	
	90 [3.54]	AR98	5, 7.2, 10	480 (108)	540 (121)	600 (135)	680 (153)	790 (177)	300 (67)
				850 (191)	940 (210)	1050 (230)	1190 (260)	1380 (310)	
				930 (200)	1030 (230)	1150 (250)	1310 (290)	1520 (340)	
				1050 (230)	1160 (260)	1300 (290)	1480 (330)	1710 (380)	
PN Geared Type	28 [1.10]	AR24	5, 7.2, 10	45 (10.1)	60 (13.5)	80 (18)	100 (22)	-	20 (4.5)
	42 [1.65]	AR46		100 (22)	120 (27)	150 (33)	190 (42)	-	
	60 [2.36]	AR66	5	200 (45)	220 (49)	250 (56)	280 (63)	320 (72)	100 (22)
				250 (56)	270 (60)	300 (67)	340 (76)	390 (87)	
				330 (74)	360 (81)	400 (90)	450 (101)	520 (117)	
	90 [3.54]	AR98	5	480 (108)	520 (117)	550 (123)	580 (130)	620 (139)	300 (67)
				480 (108)	540 (121)	600 (135)	680 (153)	790 (177)	
				850 (191)	940 (210)	1050 (230)	1110 (240)	1190 (260)	
				930 (200)	1030 (230)	1150 (250)	1220 (270)	1300 (290)	
				1050 (230)	1160 (260)	1300 (290)	1380 (310)	1490 (330)	
Harmonic Geared Type	30 [1.18]	AR24	50, 100	100 (22)	135 (30)	175 (39)	250 (56)	-	140 (31)
	42 [1.65]	AR46		180 (40)	220 (49)	270 (60)	360 (81)	510 (114)	220 (49)
	60 [2.36]	AR66		320 (72)	370 (83)	440 (99)	550 (123)	720 (162)	450 (101)
	90 [3.54]	AR98		1090 (240)	1150 (250)	1230 (270)	1310 (290)	1410 (310)	1300 (290)

● The motor product name has characters for identifying the serie's name.

*The brackets [] indicate the value for the electromagnetic brake type.

Note

● With a double shaft product, the output shaft located on the opposite side of the motor output shaft is used to install a slit disk or similar device. Do not apply any load torque, overhung load or thrust load on this output shaft.

● **RK Series, CRK Series, CMK Series, RBK Series, PK Series, PV Series**

Unit = N (lb.)

Type	Motor Frame Size mm [in.]	Motor Model	Gear Ratio	Permissible Overhung Load Distance from Shaft End mm [in.]					Permissible Thrust Load
				0 [0]	5 [0.2]	10 [0.39]	15 [0.59]	20 [0.79]	
0.72°, 1.8° High-Torque Type	20 [0.79]	PK213, PK214, PK513	-	12 (2.7)	15 (3.3)	-	-	-	The permissible thrust load shall be no greater than the motor mass.
	28 [1.10]	PK223, PK224, PK225, PK523, PK525		25 (5.6)	34 (7.6)	52 (11.7)	-	-	
	35 [1.38]	PK233, PK235		20 (4.5)	25 (5.6)	34 (7.6)	52 (11.7)	-	
	42 [1.65]	PK244, PK246, PK544, PK546		20 (4.5)	25 (5.6)	34 (7.6)	52 (11.7)	-	
	56.4 [2.22]	PK264, PK266, PK268		49 (11)	60 (13.5)	79 (17.7)	110 (24)	-	
60 [2.36]	PV264, PV266, PV267, PV269		50 (11.2)	60 (13.5)	75 (16.8)	100 (22)	150 (33)		
High-Torque, High-Efficiency Type	42 [1.65]	PKE243, PKE244, PKE245	-	20 (4.5)	25 (5.6)	34 (7.6)	52 (11.7)	-	
0.36° High-Torque Type, 0.9° Standard Type	28 [1.10]	PK523, PK524, PK525	-	25 (5.6)	34 (7.6)	52 (11.7)	-	-	
	42 [1.65]	PK243, PK244, PK245, PK544, PK546	-	20 (4.5)	25 (5.6)	34 (7.6)	52 (11.7)	-	
	56.4 [2.22]	PK264, PK266, PK268	-	54 (12.1)	67 (15)	89 (20)	130 (29)	-	
	60 [2.36]	PK564, PK566, PK569	-	90 (20)	100 (22)	130 (29)	180 (40)	270 (60)	
Standard Type, Standard Type Terminal Box	42 [1.65]	PK243, PK244, PK245, PK543, PK544, PK545	-	20 (4.5)	25 (5.6)	34 (7.6)	52 (11.7)	-	
	50 [1.97]	PK256, PK258	-	54 (12.1)	67 (15)	89 (20)	130 (29)	-	
	56.4 [2.22]	PK264, PK266, PK268	-	54 (12.1)	67 (15)	89 (20)	130 (29)	-	
	60 [2.36]	PK564, PK566, PK569	-	63 (14.1)	75 (16.8)	95 (21)	130 (29)	190 (42)	
	85 [3.35]	PK296, PK299, PK2913, PK596, PK599, PK5913	-	260 (58)	290 (65)	340 (76)	390 (87)	480 (108)	
SH Geared Type	28 [1.10]	PK223	7.2, 9, 10, 18, 36	15 (3.3)	17 (3.8)	20 (4.5)	23 (5.1)	-	10 (2.2)
	42 [1.65]	PK243	3.6, 7.2, 9, 10, 18, 36	10 (2.2)	15 (3.3)	20 (4.5)	30 (6.7)	-	15 (3.3)
	60 [2.36]	PK264	3.6, 7.2, 9, 10, 18, 36	30 (6.7)	40 (9)	50 (11.2)	60 (13.5)	70 (15.7)	30 (6.7)
	90 [3.54]	PK296	3.6, 7.2, 9, 10, 18, 36	80 (18)	100 (22)	120 (27)	140 (31)	160 (36)	100 (22)
TH Geared Type	28 [1.10]	PK523	7.2, 10, 20, 30	15 (3.3)	17 (3.8)	20 (4.5)	23 (5.1)	-	10 (2.2)
	42 [1.65]	PK543	3.6, 7.2, 10, 20, 30	10 (2.2)	14 (3.1)	20 (4.5)	30 (6.7)	-	15 (3.3)
	60 [2.36]	PK564		70 (15.7)	80 (18)	100 (22)	120 (27)	150 (33)	40 (9)
	90 [3.54]	PK596		220 (49)	250 (56)	300 (67)	350 (78)	400 (90)	100 (22)
28 [1.10]	PK223, PK523	5, 7.2, 10		45 (10.1)	60 (13.5)	80 (18)	100 (22)	-	20 (4.5)
PS Geared Type	42 [1.65]	PK545	5, 7.2, 10	73 (16.4)	84 (18.9)	100 (22)	123 (27)	-	50 (11.2)
		PK543	25, 36, 50	109 (24)	127 (28)	150 (33)	184 (41)	-	
	60 [2.36]	PK566	5	200 (45)	220 (49)	250 (56)	280 (63)	320 (72)	100 (22)
		PK564	7.2, 10	250 (56)	270 (60)	300 (67)	340 (76)	390 (87)	
	90 [3.54]	PK599	25, 36, 50	330 (74)	360 (81)	400 (90)	450 (101)	520 (117)	
			5, 7.2, 10	480 (108)	540 (121)	600 (135)	680 (153)	790 (177)	
			25	850 (191)	940 (210)	1050 (230)	1190 (260)	1380 (310)	300 (67)
			36	930 (200)	1030 (230)	1150 (250)	1310 (290)	1520 (340)	
PL Geared Type	42 [1.65]	PK244	5, 10	73 (16.4)	84 (18.9)	100 (22)	123 (27)	-	50 (11.2)
			36	109 (24)	127 (28)	150 (33)	184 (41)	-	
	60 [2.36]	PK266	5	200 (45)	220 (49)	250 (56)	280 (63)	320 (72)	100 (22)
			10	250 (56)	270 (60)	300 (67)	340 (76)	390 (87)	
		PK264	36	330 (74)	360 (81)	400 (90)	450 (101)	520 (117)	

● The motor product name has characters for identifying the serie's name.

Introduction
 AC Input Motor & Driver
 0.36° / Geared
 0.72° / Geared
 0.9°/1.8°
 DC Input Motor & Driver
 0.36° / Geared
 0.36° / Geared
 0.36° / Geared
 0.9°/1.8° / Geared
 1.8° / Geared
 Motor Only
 0.36°
 0.72°
 0.9°
 1.8°
 Geared
 Controllers
 SCX10
 EMP400
 /SG8030J
 Accessories

● RK Series, CRK Series, CMK Series, RBK Series, PK Series, PV Series

Unit = N (lb.)

Type	Motor Frame Size mm [in.]	Motor Model	Gear Ratio	Permissible Overhung Load Distance from Shaft End mm [in.]					Permissible Thrust Load
				0 [0]	5 [0.2]	10 [0.39]	15 [0.59]	20 [0.79]	
PN Geared Type	28 [1.10]	PK523	5, 7.2, 10	45 (10.1)	60 (13.5)	80 (18)	100 (22)	—	20 (4.5)
	42 [1.65]	PK544	5, 7.2, 10	100 (22)	120 (27)	150 (33)	190 (42)	—	
	60 [2.36]	PK566	5	200 (45)	220 (49)	250 (56)	280 (63)	320 (72)	100 (22)
			7.2, 10	250 (56)	270 (60)	300 (67)	340 (76)	390 (87)	
	90 [3.54]	PK564	25, 36, 50	330 (74)	360 (81)	400 (90)	450 (101)	520 (117)	300 (67)
			5	480 (108)	520 (117)	550 (123)	580 (130)	620 (139)	
	PK599	7.2, 10	480 (108)	540 (121)	600 (135)	680 (153)	790 (177)		
		25	850 (191)	940 (210)	1050 (230)	1110 (240)	1190 (260)		
		36	930 (200)	1030 (230)	1150 (250)	1220 (270)	1300 (290)		
	PK596	50	1050 (230)	1160 (260)	1300 (290)	1380 (310)	1490 (330)		
Harmonic Geared Type	20 [0.79]	PK513	50, 100	50 (11.2)	75 (16.8)	—	—	—	60 (13.5)
	30 [1.18]	PK523		110 (24)	135 (30)	175 (39)	250 (56)	—	140 (31)
	42 [1.65]	PK543		180 (40)	220 (49)	270 (60)	360 (81)	510 (114)	220 (49)
	60 [2.36]	PK564		320 (72)	370 (83)	440 (99)	550 (123)	720 (162)	450 (101)
	90 [3.54]	PK596		1090 (240)	1150 (250)	1230 (270)	1310 (290)	1410 (310)	1300 (290)

● The motor product name has characters for identifying the serie's name.

■ Permissible Moment Load (Harmonic Geared Type)

If an eccentric load is applied when attaching an arm or table to the flange face, calculate the moment load with the following formula. The moment load should not exceed the permissible values shown in the table below.

Moment Load: $M [N \cdot m (oz \cdot in)] = F \times L$

Type	Motor Frame Size mm (in.)	Permissible Moment Load N·m (oz-in)
Harmonic Geared Type	20 (0.79)	0.7 (99)
	30 (1.18)	2.9 (410)
	42 (1.65)	5.6 (790)
	60 (2.36)	11.6 (1640)

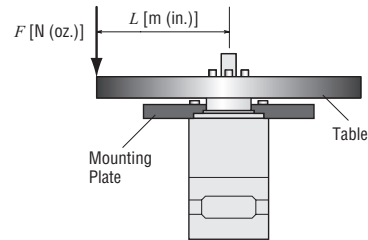

Encoder Specifications

TTL Type Encoder

◇ 0.72° **RK** Series, 0.36°/0.72° **CRK** Series Pulse Input Package, 0.36°/0.72° **PK** Series

Item	Encoder Code	Specifications			
		R17	R18	R27	R28
Type		Incremental			
Resolution		500 P/R	1000 P/R	500 P/R	1000 P/R
Output		2-Channel A, B		3-Channel A, B, Index	
Input Current		17 mA (Typ.)	57 mA (Typ.)	57 mA (Typ.)	55 mA (Typ.)
Input Voltage		5 VDC ± 10%			
Output Type		TTL			
Output Voltage (TTL)	Low	0.4 VDC, 3.2 mA (Max.)	0.5 VDC, 8 mA (Max.)	0.5 VDC, 8 mA (Max.)	0.5 VDC, 8 mA (Max.)
	High	2.4 VDC, -200 μA (Min.)	2.4 VDC, -40 μA (Min.)	2.4 VDC, -40 μA (Min.)	2.0 VDC, -8 mA (Min.)
Response Frequency		100 kHz (Max.)			

◇ 1.8° **RBK** Series, 0.9°/1.8° **CMK** Series, 0.9°/1.8° **PK** Series

• Motor Frame Size: 28 mm (1.10 in.)

Item	Encoder Code	Specifications
		R15
Type		Incremental
Resolution		200
Output		2-Channel A, B
Input Current		21 mA (Typ.)
Input Voltage		5 VDC ± 10%
Output Type		TTL
Output Voltage (TTL)	Low	0.4 VDC, 6 mA (Max.)
	High	2.4 VDC, -1.2 mA (Min.)
Response Frequency		60 kHz (Max.)

• Motor Frame Size: 35 mm (1.38 in.), 42 mm (1.65 in.), 56.4 mm (2.22 in.), 60 mm (2.36 in.), 85 mm (3.35 in.)

Item	Encoder Code	Specifications			
		R15	R16	R25	R26
Type		Incremental			
Resolution		200 P/R	400 P/R	200 P/R	400 P/R
Output		2-Channel A, B		3-Channel A, B, Index	
Input Current		17 mA (Typ.)		57 mA (Typ.)	
Input Voltage		5 VDC ± 10%			
Output Type		TTL			
Output Voltage (TTL)	Low	0.4 VDC, 3.2 mA (Max.)		0.5 VDC, 8 mA (Max.)	
	High	2.4 VDC, -200 μA (Min.)		2.0 VDC, -8 mA (Min.)	
Response Frequency		100 kHz (Max.)			

Differential Type Encoder

◇ 0.36°/0.72° **CRK** Series Built-In Controller Package, 0.36°/0.72° **PK** Series

Item	Encoder Code	Specifications
Type		Incremental
Resolution		500 P/R (0.72° High-Torque, Standard, TH-PS -Harmonic Geared Type) 1000 P/R (0.36° High-Torque Type)
Output		3-Channel A, B, Index
Input Current		500 P/R: 58 mA (Typ.)
		1000 P/R: 56 mA (Typ.)
Input Voltage		5 VDC ± 10%
Output Type		Differential
Output Voltage	Low	0.4 VDC, 20 mA (Max.)
	High	2.4 VDC, -40 mA (Min.)
Response Frequency		100 kHz (Max.)

Introduction
AC Input Motor & Driver
0.36° / Geared / ASTEP / AR
0.72° / Geared / AS / ASTEP / AS
0.9° / 1.8° / RK
0.9° / 1.8° / UMK
0.36° / Geared / AR / ASTEP / AR
0.36° / ASX / ASTEP / ASX
DC Input Motor & Driver
0.36°/0.72° / Geared / CRK
0.9°/1.8° / Geared / CMK
1.8° / Geared / RBK / ASTEP / RBK
Motor Only
0.36° / PK
0.72° / PK
0.9° / PK
1.8° / PK/PV
Geared / PK
Controllers / SCX10 / EMP400 / 5G8030J
Accessories

Encoder Pin-Outs

● TTL Type Encoder

◇ 0.72° **RK Series**, 0.36°/0.72° **CRK Series** Pulse Input Package, 0.36°/0.72° **PK Series**

Motor Pin No.	Lead Wire Color of Connection Cable for Encoder	Encoder Code	
		R17, R18	R27, R28
1	Brown	GND	
2	Purple	—	Index Channel
3	Blue	A Channel	
4	Orange	+5 VDC Power	
5	Yellow	B Channel	

◇ 1.8° **RBK Series**, 0.9°/1.8° **CMK Series**, 0.9°/1.8° **PK Series**

● Motor Frame Size: 28 mm (1.10 in.)

Motor Pin No.	Lead Wire Color of Connection Cable for Encoder	Encoder Code R15
1	Red	+5 VDC Power
2	Blue	A Channel
3	Black	GND
4	Yellow	B Channel

● Motor Frame Size: 35 mm (1.38 in.), 42 mm (1.65 in.), 56.4 mm (2.22 in.), 60 mm (2.36 in.), 85 mm (3.35 in.)

Motor Pin No.	Lead Wire Color of Connection Cable for Encoder	Encoder Code	
		R15, R16	R25, R26
1	Brown	GND	
2	Purple	—	Index Channel
3	Blue	A Channel	
4	Orange	+5 VDC Power	
5	Yellow	B Channel	

● Differential Type Encoder

◇ 0.36°/0.72° **CRK Series** Built-In Controller Package, 0.36°/0.72° **PK Series**

Motor Pin No.	Lead Wire Color of Connection Cable for Encoder	Description	Driver Pin (CN5)
1	—	N/C	9*
2	White	+5 VDC Power	7
3	Black	GND	8
4	—	N/C	—
5	Brown	A Channel—	2
6	Red	A Channel+	1
7	Blue	B Channel—	4
8	Green	B Channel+	3
9	Orange	Index—	6
10	Yellow	Index+	5

*Driver pin 9 is for shielded and is the color purple.

Encoder Dimensions

These drawings show the dimensions of only the encoder portion of the encoder-equipped motors. Check the website for the dimensions of the entire product.
www.orientalmotor.com

Encoder Dimension Table

◇ TTL Type Encoder Motor

Series	Motor Frame Size [mm (in.)]	Type (with Encoder)	Dimension No.
0.72° RK Series	42 (1.65)	0.72° Standard Type TH Geared Type PS Geared Type Harmonic Geared Type	1
	60 (2.36)	0.72° Standard Type	2
	60 (2.36)	TH Geared Type PS Geared Type Harmonic Geared Type	3
	85 (3.35)	0.72° Standard Type	4
	90 (3.54)	TH Geared Type PS Geared Type Harmonic Geared Type	5
0.36°/0.72° CRK Series Pulse Input 0.36°/0.72° PK Series	42 (1.65)	0.36°/0.72° High-Torque Type	6
	60 (2.36)	0.36° High-Torque Type	7
	42 (1.65)	0.72° Standard Type	8
	42 (1.65)	TH Geared Type PS Geared Type Harmonic Geared Type	1
	60 (2.36)	0.72° Standard Type	9
0.9°/1.8° CMK Series 0.9°/1.8° PK Series	60 (2.36)	TH Geared Type PS Geared Type Harmonic Geared Type	10
	28 (1.10)	1.8° High-Torque Type SH Geared Type	11
	35 (1.38)	1.8° High-Torque Type	12
	42 (1.65)	1.8° High-Torque Type	13
	56.4 (2.22)	1.8° High-Torque Type	14
	42 (1.65)	0.9° Standard Type 1.8° Standard Type SH Geared Type	15
	50 (1.97)	1.8° Standard Type	16
	56.4 (2.22)	0.9° Standard Type 1.8° Standard Type	17
	60 (2.36)	SH Geared Type	18
	1.8° RBK Series	28 (1.10)	1.8° High-Torque Type
35 (1.38)		1.8° High-Torque Type	12
42 (1.65)		1.8° High-Torque Type PL Geared Type	13
60 (2.36)		PL Geared Type	19
56.4 (2.22)		1.8° Standard Type	17
85 (3.35)		1.8° Standard Type	20

◇ Differential Type Encoder Motor

Series	Motor Frame Size [mm (in.)]	Type (with Encoder)	Dimension No.
0.36°/0.72° CRK Series Built-In Controller 0.36°/0.72° PK Series	42 (1.65)	0.36°/0.72° High-Torque Type	21
	60 (2.36)	0.36° High-Torque Type	22
	42 (1.65)	0.72° Standard Type	23
	42 (1.65)	TH Geared Type PS Geared Type Harmonic Geared Type	24
	60 (2.36)	0.72° Standard Type	25
	60 (2.36)	TH Geared Type PS Geared Type Harmonic Geared Type	26

Introduction
AC Input Motor & Driver
0.36° / Geared / AR
0.36° / Geared / AS
0.72° / Geared / RK
0.9°/1.8° / UMK
DC Input Motor & Driver
0.36° / Geared / AR
0.36° / Geared / ASX
0.36°/0.72° / Geared / CRK
0.9°/1.8° / Geared / CMK
1.8° / Geared / RBK
Motor Only
0.36° / PK
0.72° / PK
0.9° / PK
1.8° / PK/PV
Geared / PK
Controllers / SCX10 / EMP400 / 5G8030J
Accessories

● Dimensions unit = mm (in.)

1

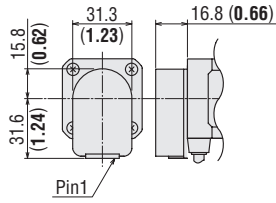

2

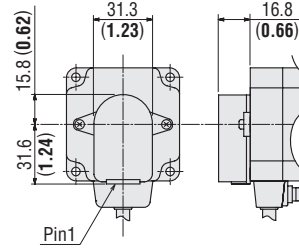

3

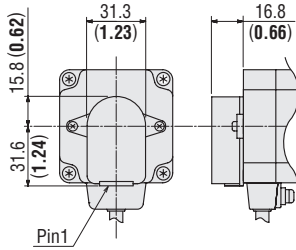

4

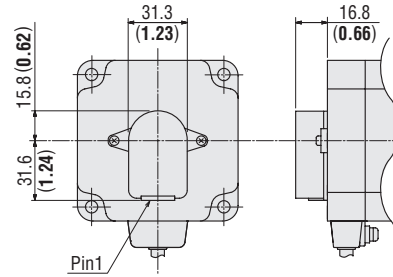

5

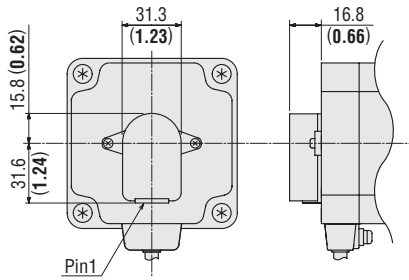

6

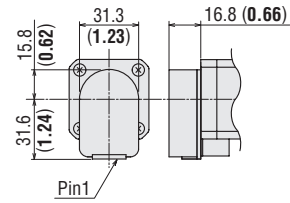

7

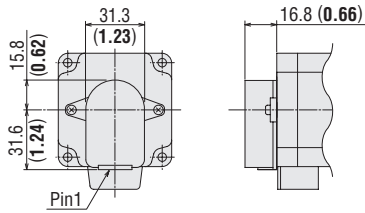

8

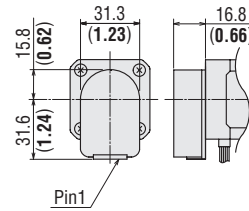

9

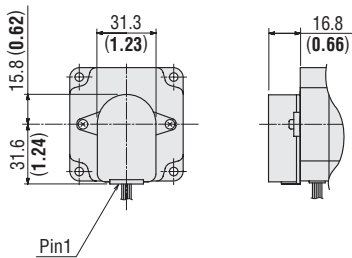

10

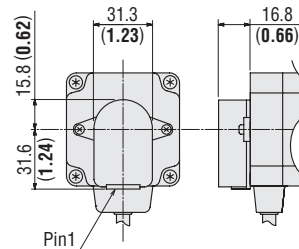

11

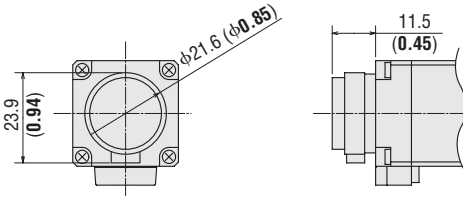

12

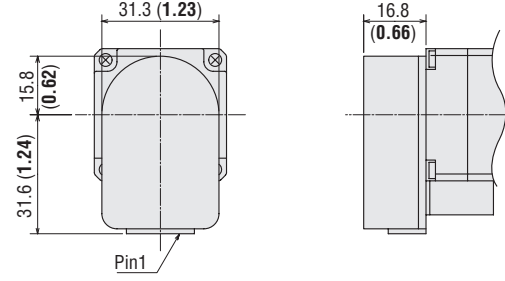

13

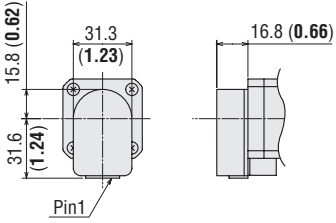

14

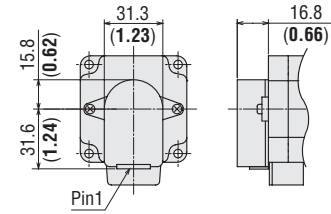

15

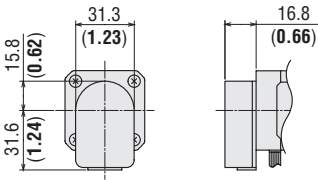

16

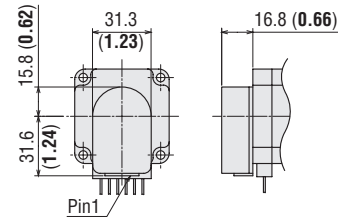

17

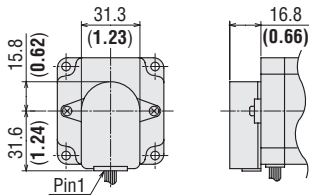

18

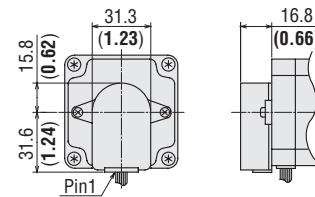

19

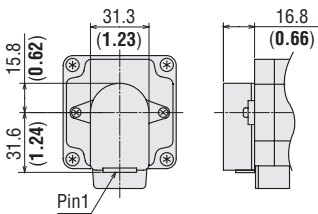

20

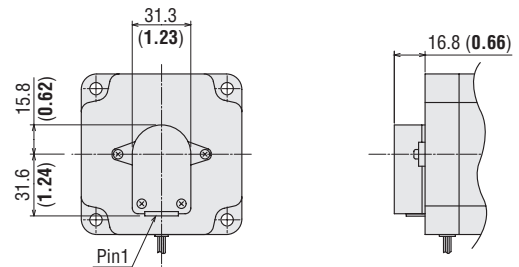

● Dimensions unit = mm (in.)

21

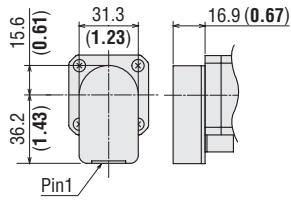

22

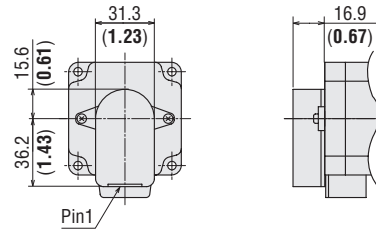

23

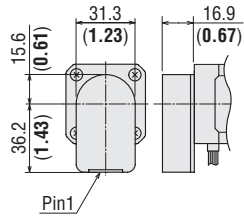

24

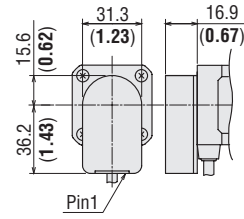

25

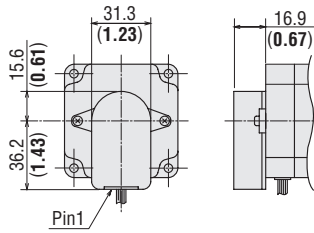

26

